

ELD MANDATE

Presents Safety and Security for
Trailers, Trucks and Drivers

Thank you

ELD Mandate
3158 Redhill Ave Suite 100
Costa Mesa, CA 92626
www.eldmandate.biz



Trailer Safety and Security Solution

EM6000; EM4000; EM200

EM6000 TRAILER SECURITY

PRODUCT OVERVIEW EM6000

- Revolutionary Top-of-the-Line 4G Smart Electronic Lock Solution To Secure And Prevent Unauthorized Usage.
- Lock Disables Crank Handle From Engaging With Landing Gear To Prevent Unauthorized Use Of Trailer.
- Only Authorized Users Can Use Crank Handle To Raise Landing Gear.
 - Cellular/Mobile App
 - Keypad Input
 - RFID Card(s)
 - Bluetooth
- Most Comprehensive / Effective Solution To Prevent The Unauthorized Misuse Or Theft Of Trailers On The Market.
- Robust Out Of The Box Customizable Real Time GPS Tracking, Geo-fencing, And Tamper Alerting / Notifications.
- 15-20 Minute/Simple Installation And Cannot Be Removed Without Heavy Duty Tooling.

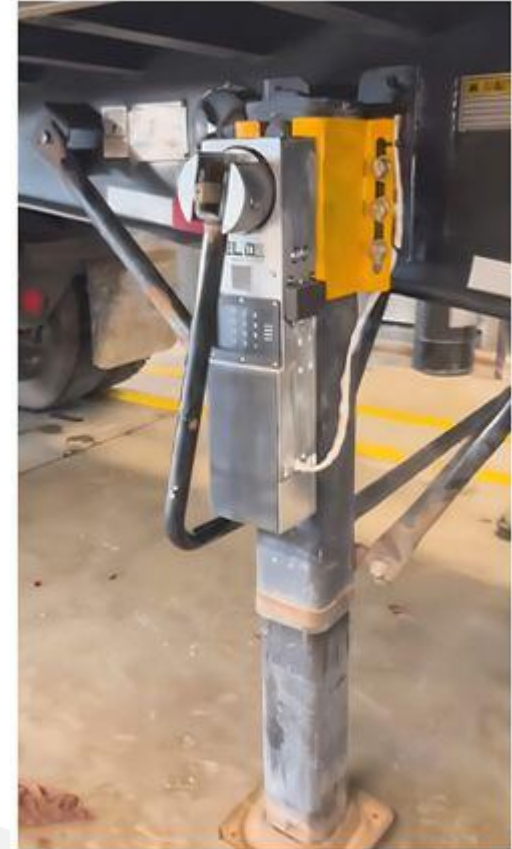

[Please Click here for product videos and more information](#)

Patents Pending

Presented By
ELD
MANDATE₂

Model EM4000

PRODUCT OVERVIEW EM4000

EM4000 is a fully AI based dual camera system for the trailers, powered by solar and rechargeable batteries. One camera is placed inside the trailer and another camera is mounted on the top front of the trailer.

- AI-Based Dual Camera System: One camera inside the trailer and one on the front, powered by solar and rechargeable batteries.
- Internal Camera Features: Detects space utilization, cargo loads, human trafficking, temperature, and more.
- External Camera Features: Captures images/videos of the driver, DOT and MC numbers, and any incidents/accidents.
- Cargo Monitoring: Uploads cargo pictures when parked and periodically while moving; detects and reports human trafficking.
- On-Demand Visuals: Provides on-demand video or pictures inside and outside the trailer.
- Security Features: Takes pictures when doors are opened, offers geo-fencing, GPS updates, and monitors for theft and incidents.

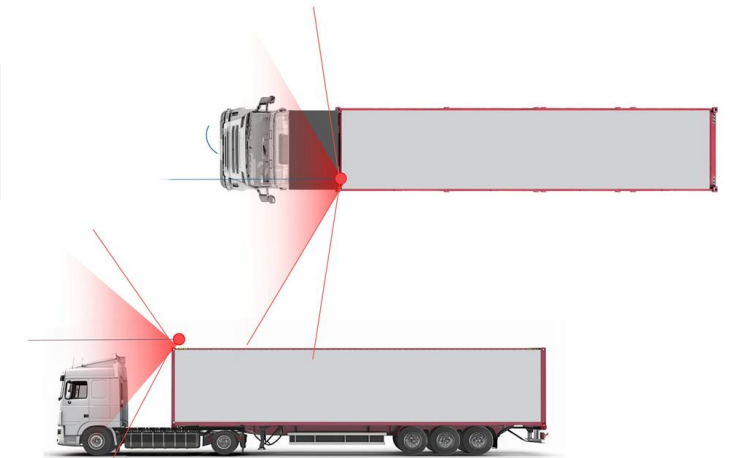

[Please Click here for more information](#)



Patents Pending



ELD MANDATE

Tail Light Tracker Model EM200/EM300/EM600

PRODUCT OVERVIEW

TAIL LIGHT TRACKER

The Tail Light Tracker is a discreet smart GPS tracker that also has all the functionality of a tail light.

- Discreet Smart GPS Tracker: Functions as a tail light, making it hidden and easy to install.
- Continuous Charge: Charges automatically when headlights or brake lights are on.
- Near Real-Time Tracking: Provides near real-time location tracking and sharing.
- Speeding and Geo-Fence Alerts: Sends automatic alerts for speeding and geo-fence breaches.
- Remote Finding: Features flashing lights and a buzzer for easy location and alarm creation.
- Durability: IP67 waterproof and dust-resistant.
- Easy Installation: Can be installed quickly by anyone, reducing installation costs.
- Hidden Design: Discreet and hidden, making it difficult for unauthorized people to remove.
- Anti-Theft Features: Addresses the rise in trailer theft with hidden design and remote flashing light option.



[Please Click here for product videos and more information](#)



[Please Click here for product videos and more information](#)



ELD
MANDATE

Truck and Driver Safety and Security ELD and Dash Cam 10BIZ332; EM6120; ELDs

PRODUCT OVERVIEW FOR MODEL 10BIZ332

- Android-Based 10.1 Inch Rugged Tablet: Larger display for easier viewing of logs and functions.
 - Dual Connectivity: Connects to ELD device via Bluetooth or can be hard-wired easily.
 - Complete Bundle: Includes heavy-duty mount, charging cables, and all necessary accessories.
 - 4G/LTE Enabled: Supports various business applications, Hours of Service, and truck routing maps.
 - Optional Integrated Dash Cam: option to make it a roadside-facing dash cam. SD card provided.
 - Compliance Issues: Addresses FMCSA compliance problems associated with Bluetooth-only ELDs.
 - Cost-Effective: Offers a more affordable hard-wired option compared to other vendors.
 - Enhanced Visibility: Larger display size (10.1 inches) compared to the typical 7 or 8 inches.4.
- Versatile Use: The tablet can be used for multiple business applications beyond ELD.



[Please Click here for more information](#)



[Please Click here for product videos and more information](#)

ELD
MANDATE

Dash Cam Model EM6120

PRODUCT OVERVIEW

ELD Mandate offers a few different dash cams depending upon the application and requirements of the trucking company. These include:

- Dual Camera dash cam 4G/LTE – Regular dash cam that has all dash cam features except for the AI.
 - EM18 – 360 degrees lens with an additional rear camera. Works as 5 cameras with 2. No AI.
 - EM6120 – This is a full featured 4G/LTE dash cam with ADAS (advanced assisted driving system) ; driver monitoring system (DMS), Lane changing assistance (LCA) and many more features. Some of the main features include:
 - A) Forward Collision Warning
 - B) Pedestrian Collision Warning
 - C) Lane Departure Warning
 - D) Virtual Bumper
 - E) Stop and Go
- DMS Functions:
- A) Fatigue Driving
 - B) Distraction Driving
 - C) Smoking Warning
 - D) Cell Phone Calling Warning
 - E) Seat Belt Detection

EM 6120 also comes with an additional camera that can be put in the side or in the rear. There is an external GPS Antenna for better location accuracy, Emergency Alarm Button for the driver; ACC Hard wire kit and other accessories are included with the device.



GPS Signal

4G Signal

Video Recording

[Please Click here for product videos and more information](#)



[Please Click here for product videos and more information](#)

ELD
MANDATE

ELD Mandate Executive Summary

- Created to provide a user-friendly app for truck drivers to record daily activity.
- Leveraged web design and custom app building expertise.
- Now the number one rated ELD in the US and Canada.
- Evolved into a full-service IoT company for various industries (State and Local Government, Construction, Service Industries, Charter Bus Services).
- Aims to be the top-rated IoT provider across its portfolio.
- Positioned to capitalize on explosive IoT growth.
- Offers 24/7 customer phone service for immediate support.
- Focuses on high quality, competitive pricing, and excellent support.
- Disruptive IoT technologies since 2017.
- Trusted by over 10,000 fleets and companies.



- Products include Tail Light Tracking device, Trailer Smart Lockdown System EM6000, AI-based Trailer and Cargo Camera System, rugged 10.1 inch 4G/LTE Android Tablets, AI-based Dash Cam with ADAS and DMS.
- Customizable workflow apps to digitize paperwork.
- Customer base grows through referrals.
- Maintains strong customer relationships for continuous improvement.
- Trade show presence and integration/channel partners drive expansion.
- Several large projects under NDA with high growth potential.
- Custom solutions and in-house development teams provide a competitive edge in the IoT field.

